

# Flow

## Piston Digital Control Valves



Vermont Piston Digital Control Valve is a piston type valve, designed primarily for digital control of loading rack application. It is an electrically actuated, hydraulically operated multi-function valve. When used with a flow meter and an electronic batch controller, it can perform local as well as remote controlled precision batching operations. The Piston Digital Control Valve also offers an in-built flow governing function, when used with an electronic batch controller.

### DESIGN FEATURES

- Fail-safe design : the valve is held closed upon loss of electric supply and/or line pressure
- Positive shut-off : meets ANSI Class VI for bubble-tight closure
- Multi-stage opening and closing : avoids static charge generation due to splashing of product in the beginning and foaming / overflow at the end, resulting in accurate delivery
- Low pressure drop
- Rectangular ports : for uniform valve response and linear control
- Built-in flow rate control : no need of external pilots for flow rate control, when used with electronic batch controller
- No diaphragm

### CONSTRUCTION

The Alma Piston Digital Control Valve basically consists of a spring loaded piston, sliding in the guide liner, and two solenoid valves. Piston chamber formed between the liner and the piston top, is connected to the upstream and downstream pressures by normally open (NO) and normally closed (NC) solenoid valves respectively.

### PRINCIPLE OF OPERATION

The Alma Piston Digital Control Valve works on the principle of "balanced piston".

Piston is always exposed to high upstream pressure from its bottom side, whereas pressure in the piston chamber can be varied with the help of solenoid valves. When pressure in the piston chamber is equal to the high upstream pressure, the top spring acts as a differential force, pushing the piston down on the valve seat and the valve is held tightly-closed.

When pressure in the piston chamber is relieved with the help of solenoid valves, a differential pressure is



created across the piston. The high upstream pressure below the piston overcomes the top pressure plus the spring force and pushes the piston up, resulting in valve opening and the flow starts.

### DIGITAL CONTROL

When the Piston Digital Control Valve is used with an electronic batch controller, it can be digitally controlled by operating the solenoid valves through any of these three stages :

- when NO and NC solenoids are energised, the valve opens gradually.
- when NC solenoid is de-energised (keeping NO solenoid energised), the valve locks at its current position.
- when NO and NC solenoids are de-energised, the valve closes gradually.

### MULTI-STAGE OPERATION

Opening and closing of the Piston Digital Control Valve can be made in multiple stages, when the valve is configured for digital control using an electronic batch controller. A typical loading cycle with multi-stage opening and closing is explained in figure 1.

Initially, both NO and NC solenoid valves are in de-energised condition, resulting in complete closure of the valve.

When both solenoid valves are energised, the pressure in the piston chamber starts relieving to the downstream side, creating a differential pressure across the piston. The high upstream pressure below the piston pushes it up in the liner, allowing the flow to gradually start.

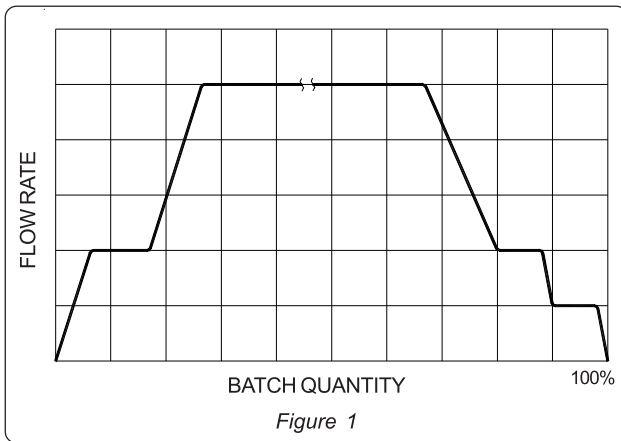

When the flow rate reaches an intermediate stage, NC solenoid valve is de-energised. This stops relieving of pressure in the piston chamber and the valve locks at the current flow rate.

After allowing some quantity to pass at this intermediate flow rate, NC solenoid is energised again. This further relieves the chamber pressure, resulting in further increase in the flow rate. When the set high flow rate is reached, NC solenoid is de-energised to lock the valve at this flow rate. Most part of the loading takes place at this flow rate.

Towards the end of the delivery, both NO and NC solenoid valves are de-energised. This applies high upstream pressure over the piston, resulting in a gradual drop in the flow rate. When the flow rate reaches an intermediate value, NC solenoid is energised again to lock the valve at this flow rate. When loading of the set quantity is complete, NC solenoid is de-energised, which pushes the piston down to close completely over the valve seat and achieve bubble-tight shut-off.

## RATE OF FLOW CONTROL

If the same pump is used to feed a number of flow meters, stopping (or starting) one or more meters increases (or decreases) the flow rate at the remaining meters. The Alma Piston Digital Control Valve offers built-in flow rate control through electronic batch controller.

When the flow rate increases, NO solenoid is energised momentarily to inject some amount of high pressure over the piston and it makes the valve to throttle, in order to maintain the set flow rate.

When the flow rate decreases, NC solenoid is energised momentarily to slightly drain the pressure and it allows the valve to open further, in order to maintain the set flow rate.

**Note :** The number of stages during opening and closing are programmed in the electronic batch controller and can be as many as desired. One stage during opening and two during closing are recommended.

**Caution :** Sufficient pumping flow rate should be available to achieve the flow parameters set in the electronic batch controller. In the absence of this, there are chances of delayed response in closure, resulting in valve over-run.

## INSTALLATION

The Piston Digital Control Valve should be connected on the discharge side of the pump. It is not designed for use on the suction side of the pump. For a proper operation, it should be located preferably on the downstream side of the flow meter, so that the meter always remains full of liquid for best metering accuracy.

## OPTIONS

- 2)21 The Piston Digital Control Valve can be supplied with external stem and limit switches. Signals from the switches can be used monitor the flow rate(s) and/or to indicate the valve position - open or closed.
- 2)21 Standard valve is supplied with 230 V AC solenoids, other voltage solenoids can be supplied on request.

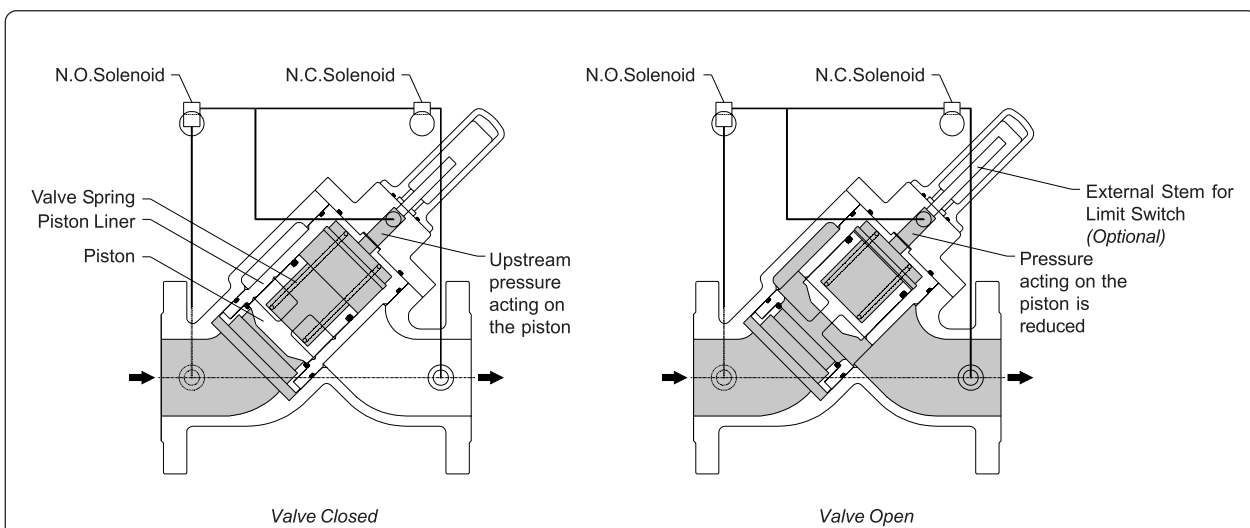

## OTHER USES

### TWO-STAGE SET STOP VALVE

The Piston Digital Control Valve can be configured as a simple, two stage set-stop valve. In this, the valve opens wide on energising both solenoids, throttles to a slower flow rate on de-energising NC solenoid and closes on de-energising both solenoids. Field-adjustable maximum flow stop can also be provided, using a limit switch.

Opening and closing speeds are adjusted on the needle valves, optionally provided in the control circuit. Two-stage set stop valve is ideally suited for remote control application, without using electronic batch controller.

### CHECK VALVE

The Piston Digital Control Valve can be configured as a check valve or non-return valve, to prevent the flow of product in reverse direction.

CONTROL VALVE SPECIFICATIONS	
Line Size	3" (80 mm)
	4" (100 mm)
Pressure Rating	150 Class / 300 PSI
Flow Range	2000 lpm (3")
	2500 lpm (4")
Shut-off Class	ANSI Class VI
Body Material	Steel ASTM A 216 WCB
Piston Material	Phosphor Bronze
Seals	Nitrile
	Viton
Seat Ring	Stainless Steel 304
Spring	Stainless Steel 304
Stem Switch	Optional
Needle Valve	Optional
Solenoid Valve	Digital flow control with 1 NO and
	1 NC solenoid valves. 110/230VAC
Temperature	70°C
End Connections	ANSI B16.5 RF, Class 150 / Class 300

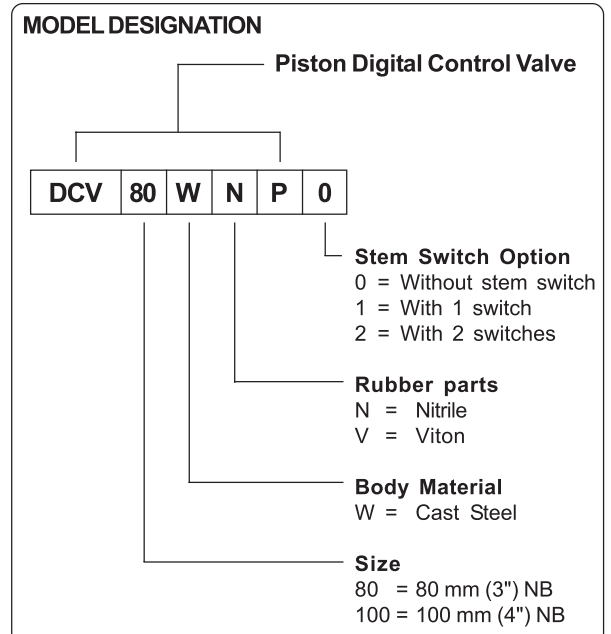
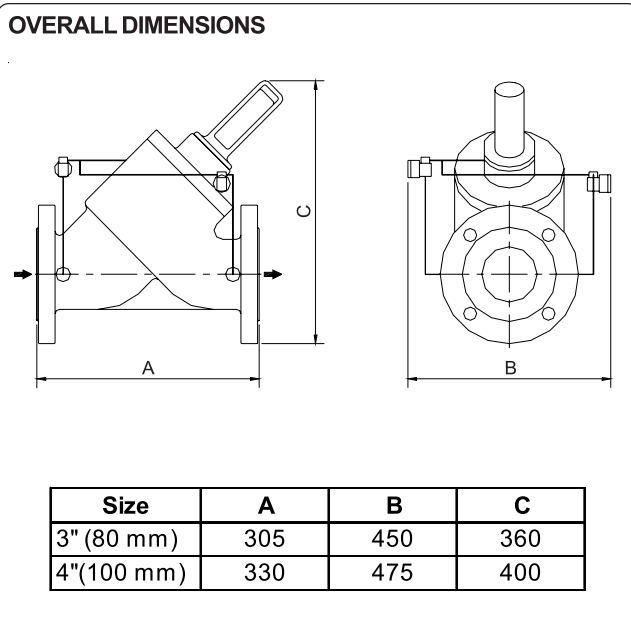

- Specifications are subject to change without notice.
- All dimensions are in mm unless otherwise specified.

Pub. No. 001  
Issue 1 Rev 0 08-2012

---

## ***Vermont Technologies Pvt. Ltd.***

### **Corporate Office & Operations:**

Plot No. PAP-A-8/6, "A" Block, Phase IV, MIDC Chakan, Opp Mahindra Vehicle, Dist. Pune - 410 501.

Tel : +91 20 32420419

E-mail : [ho@vermonttechnologies.co.in](mailto:ho@vermonttechnologies.co.in)

Website : [www.vermonttechnologies.co.in](http://www.vermonttechnologies.co.in)