

Flow



TL Series PD Flow Meters (3" to 8")

The TL Series Positive Displacement Flow Meters are precision made liquid measuring Flow Meters. These are available in single, double and triple capsule models to suit applications covering a wide range of flow capacities. Simplicity of design and construction ensures unmatched accuracy and trouble-free operation over long periods of use.

DESIGN FEATURES

- Unique wear compensating vane design for sustained accuracy over a wide flow range
- Separate meter manifold prevents pipeline stresses from being transmitted to the measuring chamber
- Pressure balanced end covers protect distortion of measuring chamber due to line pressure
- Modular construction ensures interchangeable parts, lower inventory of spares and ease of service
- Stepless calibration adjustment
- Low pressure drop
- Mechanical or electronic readout

PRINCIPLE OF OPERATION

The product enters the Flow Meter through the manifold inlet and causes the rotor to revolve by pressure on the vane blades (see figure overleaf). The proximity of the rotor to the body forms an efficient seal, whilst the profile of the body ensures that the vane blades are guided through the measuring crescent. The vane blades divide the liquid into segments and each revolution of the rotor displaces four such segments.

Pressurised product also fills spaces between the inner and outer end covers, so that the inner end covers, which form the measuring chamber, are *pressure balanced* and are prevented from distortion due to line pressure.

The rotor spindle transmits the drive through a pressure tight lip seal in the meter's front cover to the pulse transmitter or the calibrating mechanism to calibrate the meter output for a corrected counter readout. All mechanical PD Flow Meters are fitted with Veeder Root counter.

APPLICATIONS

- Aviation refuelling
- Tank truck and rail wagon gantry filling
- Ship bunkering and barge loading
- Refineries
- Tank calibration
- Test rigs
- Blending and batching in lube plants, process control and chemical industries
- Microprocessor based automation, remote control and data acquisition systems



Meter Model TL-03/04 with Veeder Root 7887 Counter



Meter Model TL-03/04 with Veeder Root EMR 3 Counter



Meter Model TL-15/16 with Pulsar

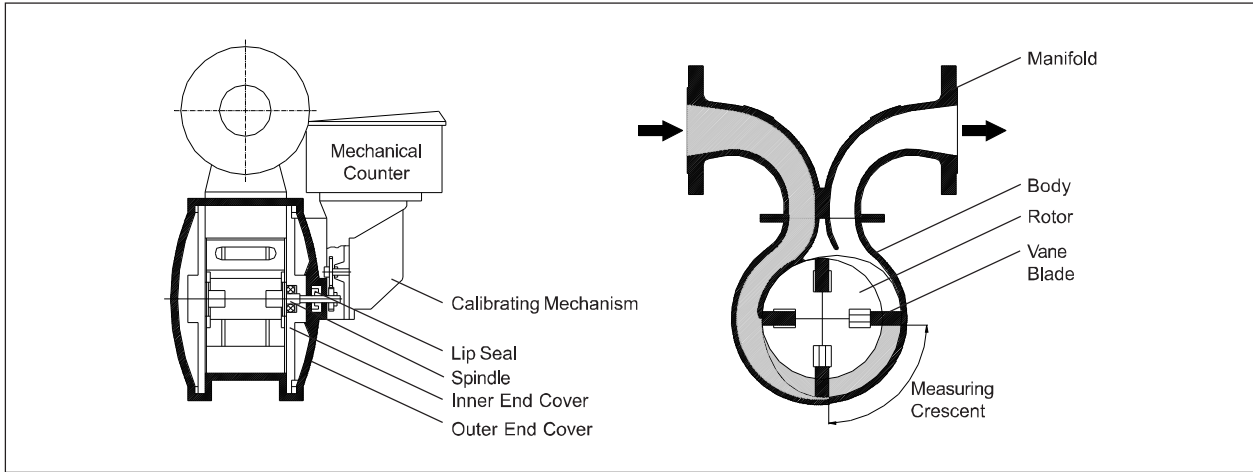

SPECIFICATIONS

Type : Positive displacement rotary vane

Sizes & Capsule : 3" to 8"

Flow Capacity : 130 LPM to 5500 LPM
34 GPM to 1448 GPM

(Maximum flow rates can be uprated by 30% for ATF and certain liquids)

Typical Performance

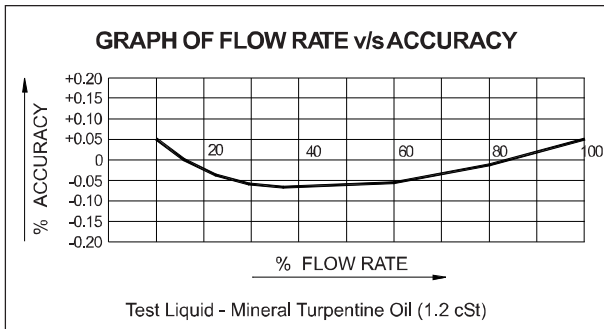

Accuracy : Better than $\pm 0.10\%$ with mechanical readout and $\pm 0.05\%$ with electronic readout

Repeatability : Better than $\pm 0.02\%$

Rangeability : 100% to 10% of maximum flow rate

End : 150 Class, ANSI B 16.5, FF/RF

Connections

(Other standards are available on request)

Meter Hand of : Left hand entry, right hand discharge

Discharge (when facing the counter) : (for even meter model nos.)

Right hand entry, left hand discharge (for odd meter model nos.)

Drive : Positive gear train

Unit of Registration : Litres

Pressure Rating : 150 PSI
300 PSI (Optional)

Temperature : Upto 70°C (Standard)
Upto 140°C (Special)

Viscosity : 0.5 cst to 200 cst
(Consult us for liquid viscosity above 200 cst)

MATERIALS OF CONSTRUCTION

(A) Meter	
Meter Housing	Cast Steel Stainless Steel
Rotor	Aluminium Alloy Stainless Steel
Vanes	Resin impregnated Morganite CY10C
Bearings	Stainless Steel
Manifold	Cast Steel Carbon Steel (Fabricated)
Rubber Parts	Buna-N (Nitrile), Viton
(B) Preset Valve	
Housing	Aluminium Cast Steel
Other Wetted Parts	Aluminium Alloy and Stainless Steel
(C) Strainer / Air Eliminator	
Housing	Carbon Steel Stainless Steel
(D) Y Type Strainer	
Housing	Carbon Steel Stainless Steel



3" Meter with Electronic Configuration

Single Capsule Meter

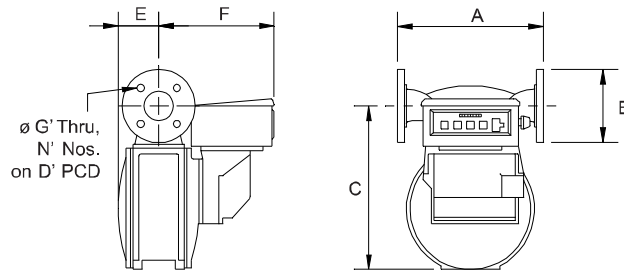

Double Capsule Meter

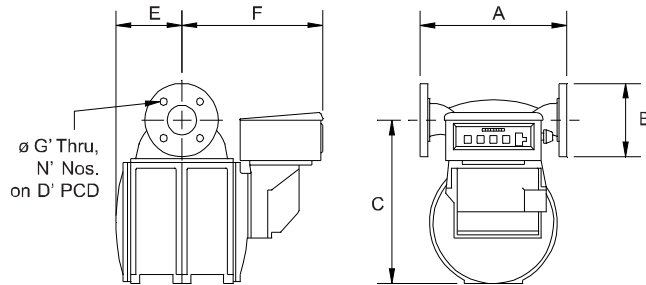

Triple Capsule Meter

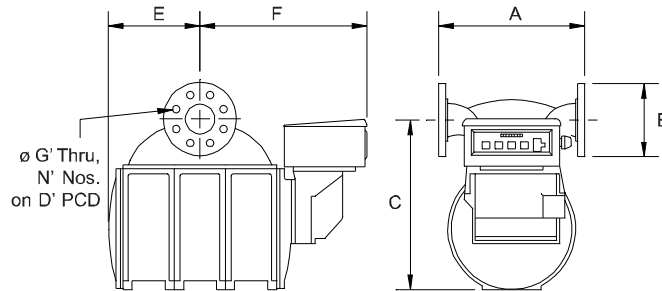

Quadruple Capsule Meter

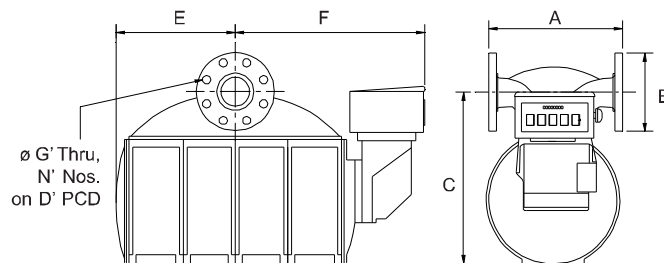

Model	Size	Capsule	Flow Rate		Dimensions								Weights	
			Min	Max	A	B	C	D	E	F	G	N	kgs	Lbs
TL-03	80 mm (3")	Single	136	1500	356	190.5	408	152.4	104	283	19	4	65	142
TL-04					400									
TL-05	80 mm (3")	Double	205	2100	432	190.5	408	152.4	168	347	19	4	95	209
TL-06					400									
TL-07	100 mm (4")	Double	227	2300	432	228.6	428	190.5	168	347	19	8	101	222
TL-08					400									
TL-09	100 mm (4")	Triple	295	3000	584	228.6	428	190.5	232	411	19	8	135	296
TL-10					400									
TL-11	150 mm (6")	Triple	295	3000	585	279.4	428	241.3	232	411	22	8	146	322
TL-12					400									
TL-13	150 mm (6")	Quadruple	500	5000	585	279.4	441	241.3	295	475	22	8	188	413
TL-14					400									
TL-15	200 mm (8")	Quadruple	550	5500	585	342.9	508	298.4	295	475	22	8	198	436
TL-16					400									

* Dim. "A" depends on construction and manifold. * Weights are for meter without counter.

A. Counters

Veeder Root 7887 or Vermont V01 for volume indication, 5 digit large numerical Reset with 8 digit non-reset totalizer. Liters, Decaliters, Gallons indication.



Veeder Root 7889 or Vermont V02 Preset Counter select predetermined volume for precise batch control.



VeederRoot EMR3 Electronic display counter with remote indication, 4-20 mA output, data logging facility.



Veeder Root Ticket Printer 7888 provides an imprinted ticket for delivery transactions. Accumulative or Zero start options available.



Electronic Registration Ex proof as well as Panel mounted WP options to perform multiple functions and pulse output, Rs232/ 485 communication.



B. Pulse Transmitter

The electronic pulse signal output, to transmit to other electronic device for indication, flow control or data acquisition.



C. Strainer and Air Eliminator

For efficient operation of meter removes free air or vapour and protection from debris entering into the flow meter



D. Flow Governor

A protective device, installed downstream of the flow meter, to limit the flow rate through the flow meter to the maximum meter flow rate capacity.



E. Mechanical Preset Valve

Preset valves provide an accurate and automatic control of a predetermined quantity of liquid to be delivered through the PD flow meter. A typical preset arrangement consists of a preset Valve mounted on the PD flow meter outlet and connected by a mechanical linkage to the preset register fitted below the PD flow meter counter.



F. Digital Control Valve

Electrically actuated, hydraulically operated multifunction control valve. The valve also offers an In-built flow governing function. Diaphragm or Piston.



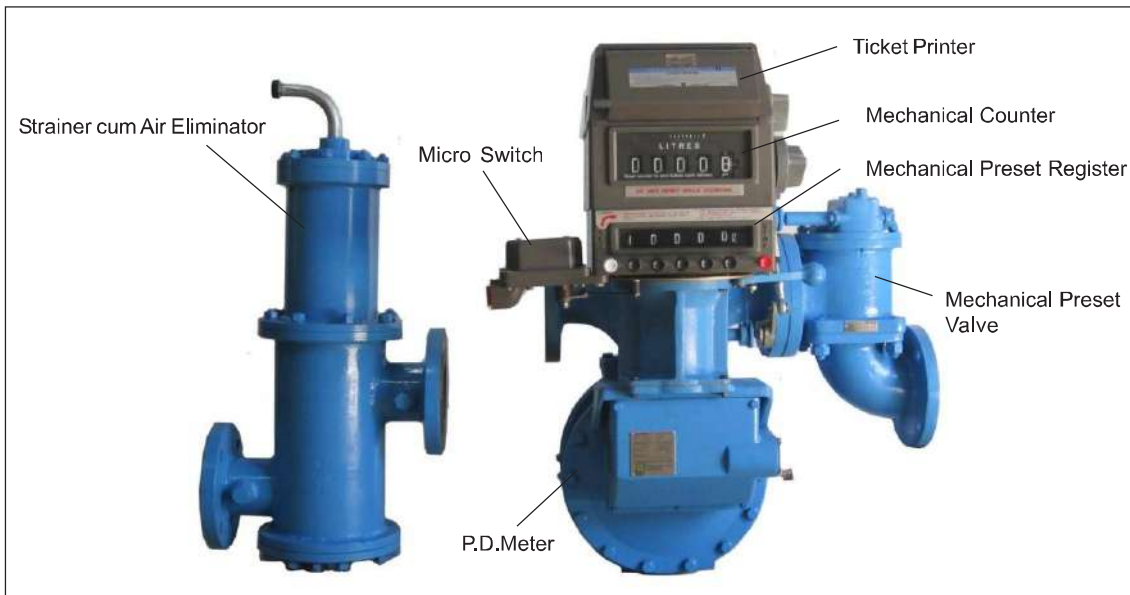

3" Preset Metering Package

ORDERING INFORMATION

Application	Batching, Loading, Blending, etc
Operating Conditions	Liquid : Name Flow Range Temperature Range Max Working Pressure Viscosity Range
Unit of Registration	Gallons, Liters Dekaliters
Direction of Flow	Left to right is standard and will be supplied unless right to lefts specified
Accessories	As required



METER MODEL DESIGNATION

PD Flow Meter

- 03 = 80 mm (3"), single capsule, LHD
- 04 = 80 mm (3"), single capsule, RHD
- 05 = 80 mm (3"), double capsule, LHD
- 06 = 80 mm (3"), double capsule, RHD
- 07 = 100 mm (4"), double capsule, LHD
- 08 = 100 mm (4"), double capsule, RHD
- 09 = 100 mm (4"), triple capsule, LHD
- 10 = 100 mm (4"), triple capsule, RHD
- 11 = 150 mm (6"), triple capsule, LHD
- 12 = 150 mm (6"), triple capsule, RHD
- 13 = 150 mm (6"), quadruple capsule, LHD
- 14 = 150 mm (6"), quadruple capsule, RHD
- 15 = 200 mm (8"), quadruple capsule, LHD
- 16 = 200 mm (8"), quadruple capsule, RHD

TL 04 W N M 7887

Counter

- 7887 = Veeder Root 7887
- V01 = Vermont Counter
- EMR3 = Veeder Root EMR3
- 0 = In case of Electronic registration

Options

- M = Mechanical
- E = Electronic

Rubber Parts

- N = Nitrile
- V = Viton

Housing Material

- W = Cast Steel
- S = Stainless Steel

- Specifications are subject to change without notice.
- All dimensions are in mm unless otherwise specified.

Pub. No. 002
Issue 2 Rev 3 11-2017

Vermont Technologies Pvt. Ltd.

Corporate Office & Operations:

Plot No: PAP- A-8/6, " A" Block, Phase IV, MIDC Chakan, Opp Mahindra Vehicle, Dist:Pune- 410501

Tel. : +91 9168179461 / +91 9168176683

Email : ho@vermonttechnologies.co.in

Website : www.vermonttechnologies.co.in